



ZİRVE CIVATA A.Ş.

“Bağlantının Zirvesi”





Hayatın her alanında...

HAKKIMIZDA

Zirve Cıvata A.Ş kuruluşundan itibaren kendi sektöründe en üst sıralarda yer almış, geliştirdiği yenilikler ve teknolojik alt yapıyla çok geçmeden sektöründe öncü firmalar arasında yerini almıştır.

Şirketimiz 2006 yılında İSTANBUL İkitelli Organize Sanayi Bölgesinde 1.000 m2 kapalı alanda pul (rondela) imalatıyla faaliyetine başlamıştır. 2010 yılında Esenyurt ISISO Sanayi Sitesi'nde 2.000 m2 kapalı imalat alanı ve 900 m2 kapalı depolama alanına genişleyen şirketimiz kaliteli hizmet, güçlü stok ve müşteri memnuniyetiyle sektöründe zirvedeki yerini sağlamlaştırmıştır. Üretim kapasitemizi arttırmak adına 2019 yılında Bursa Gemlik'te açılan 2.000 m2 kapalı imalat ve depolama alanı bulunan fabrikamız; otomotiv, beyaz eşya ve mobilya sektörüne ağırlıklı hizmet vermektedir. Büyüyen imalat kapasitesi ve geniş ürün yelpazesi ile faaliyetlerine devam etmektedir.

60'dan fazla ülkeye ihracat yapan şirketlerin en büyük tedarikçisi olan firmamız bugün, 70 kişilik profesyonel çalışma ekibi ile faaliyet alanının önde gelen bağlantı elemanları firmalarındandır.

Zirve Cıvata A.Ş sektöründe uzun yıllar edindiği deneyim ve tecrübe ile, mümkün olan en iyi servisi, en uygun fiyatla kaliteden ödün vermeden sunma prensibiyle yoluna devam ederken almış olduğu TSE CE ISO 9001 belgeleri ile bu kalitesini bir kez daha kanıtlamıştır.

Zirve Cıvata Inc. is been the top of its segment and also become one of the leading companies in the sector with the regard of companie's own development areas & technological infrastructure from the date of establishment to the present.

The company started its operation in 2006 Istanbul-located with the production of rondela in a 1000 square meter closed area with the address of İkitelli OSB. This company complex reached its capacity in Esenyurt ISISO in 2010, with 2000 square meters of indoor space and 900 square meters of storage area and provides its strength in the sector with the help of quality service, max stock and customer satisfaction. Our factory provides sectoral services and support to automotive, whiteware and furniture groups with 2000 square meter closed area and manufacturing facility opened in Bursa - Gemlik location in 2019 to expand production capacity. We continue to grow with our ever-increasing production capacity and multi-choice product range.

Export operations still continues unabated as the largest of the companies trading in more than 60 countries with the support of our 70-person working team.

As Zirve Cıvata Inc.; through our sectoral experience and knowledge, we are tendering the best service and our service continues its activities in the sector without sacrificing the most suitable price rate and also its quality with the proof of quality certificates of TSE CE ISO 9001.

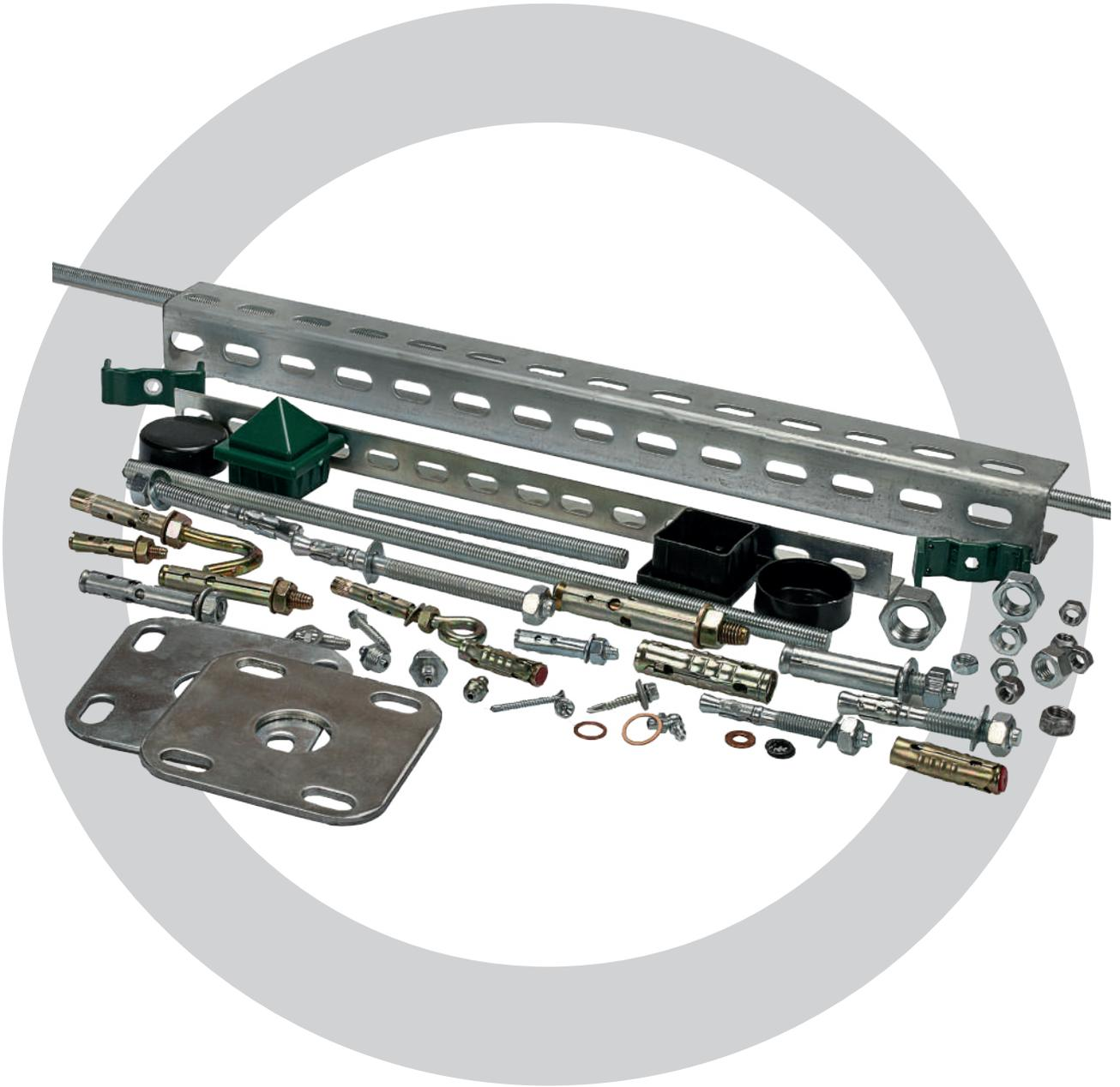

İÇİNDEKİLER

CIVATA / BOLT	04
SOMUNLAR / NUTS	04
PULLAR / WASHERS	05
VİDALAR / SCREWS	05
YAYLI RONDELA / SPRING WASHER	06
KOPİLYA / SPLIT PINS	06
FİRKETE	07
DÜBELLER / ANCHORS	07
GİJON / ROD	08
ALÜMİNYUM ve BAKIR PULLAR / ALUMINUM and COPPER WASHER	08
SUPER O-RING PULLAR / SUPER O-RING WASHER	09
GRASÖRLÜK / GRASE FITTING	09
PERFORE KANALLAR / PERFORATED CHANNELS	10
PANEL ÇİT / PANEL FENCE	10
KAPI KOLU PULLARI / HAND DOOR WASHERS	11

CIVATA

BOLT



SOMUNLAR

NUTS



**YAYLI
RONDELA**
SPRING WASHER





GIJON

ROD

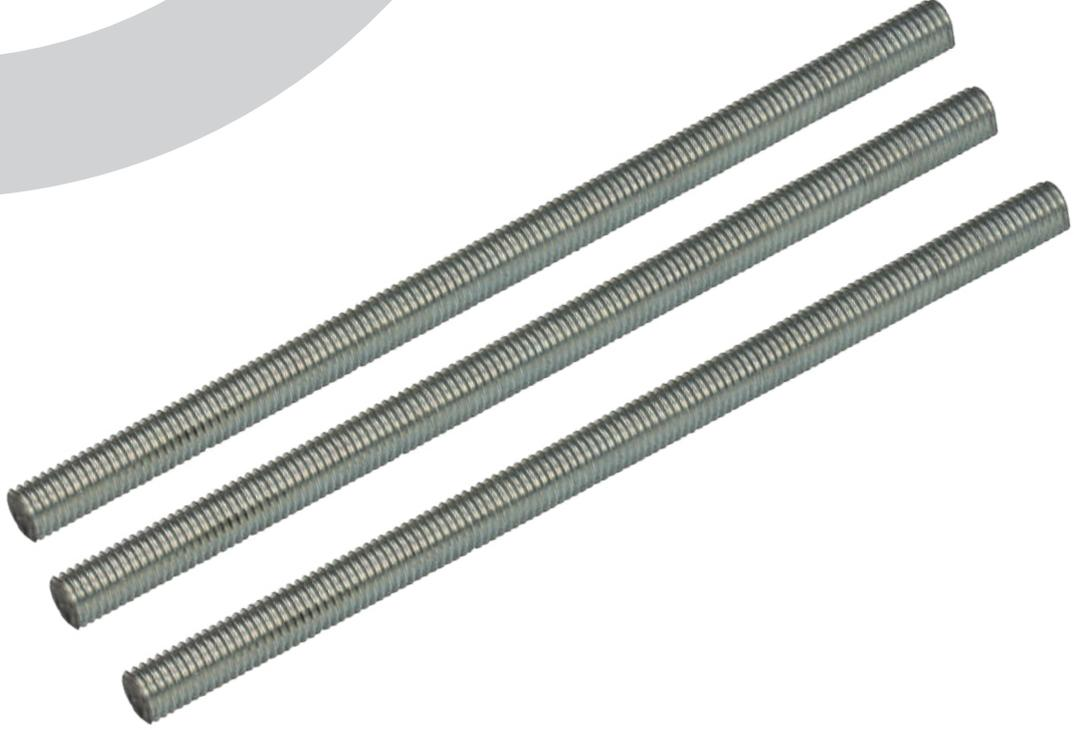

ALÜMİNYUM
ve BAKIR PULLAR
ALUMINUM and
COPPER WASHER

**SUPER
O-RING PULLAR**
SUPER O-RING
WASHER



PERFORE KANALLAR

PERFORED
CHANNELS

Z ZİRVE CIVATA A.Ş

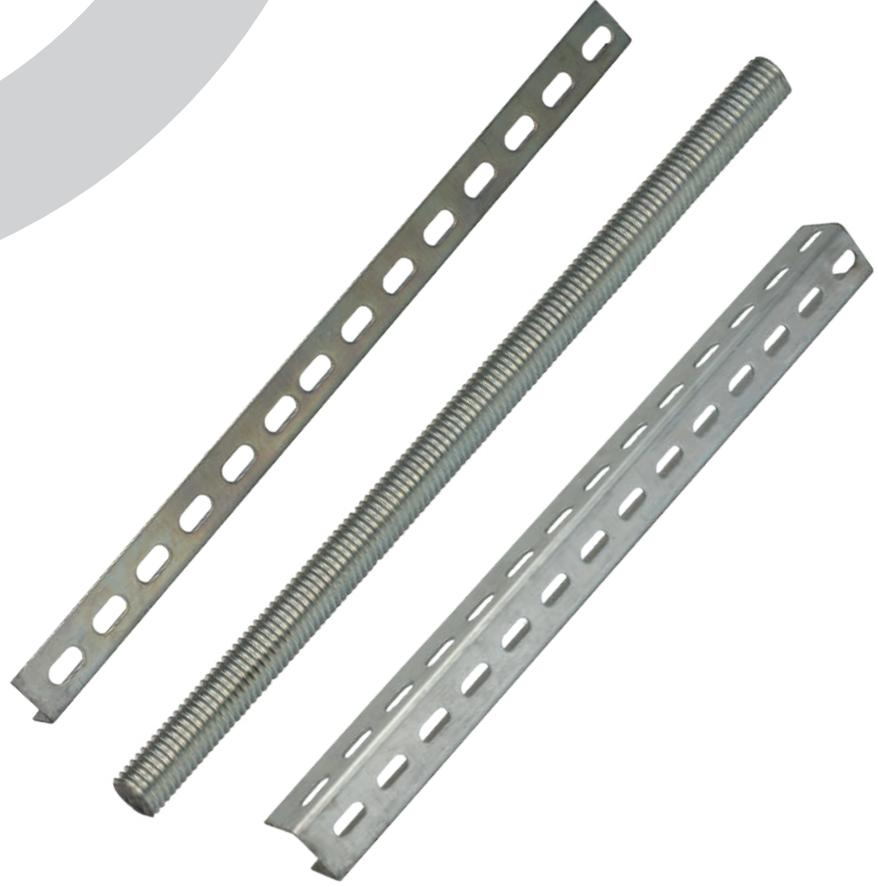

PANEL ÇİT
PANEL FENCE

KAPI KOLU PULLARI

HAND DOOR
WASHERS





Türkiye'nin En Büyük Pul İmalatçısı

Turkey's Largest Washer
Manufacturer

 **ZİRVE CIVATA A.Ş.**



0 (212) **623 03 19-20**



Orhangazi Mah. Isıso San. Sitesi HadımKöy / İstanbul



info@zirvecivata.com www.zirvecivata.com